

High Performance Cantilever Gate Hardware

Accommodates
4400 lbs at 65ft opening
7000 lbs at 30ft opening

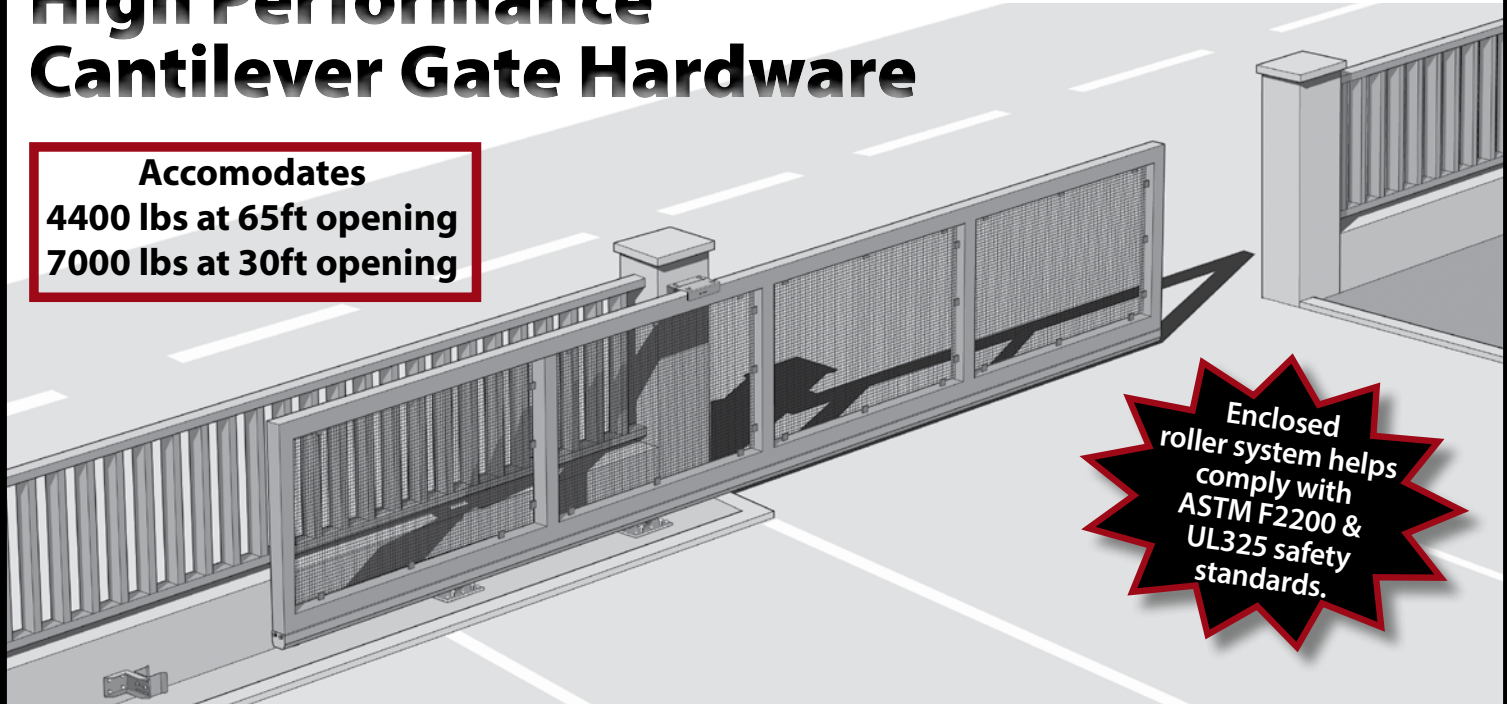

Enclosed roller system helps comply with ASTM F2200 & UL325 safety standards.

Installation Instructions

TABLE OF CONTENTS

PREPARATION OF THE FOUNDATION.....	2
J-BOLT / TIE ROD INSTALLATION	3
SET THE CARRIAGES	4
ATTACHING THE GATE TO THE TRACK.....	5
INSTALL THE END WHEELS	6
INSTALL THE MOUNTING BRACKETS.....	6
INSTALL BOTTOM END CUPS TO THE MOUNTING BRACKET	6
INSTALL THE GATE RECEIVER.....	6
INSTALL THE TOP GATE GUIDE.....	7



Manufactured in Italy by
COMUNELLO
LIFE MADE EASY

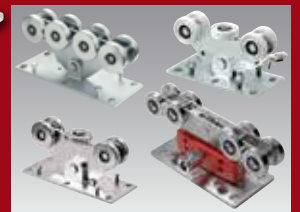

STEP 1 - PREPARATION OF THE FOUNDATION

Prepare the foundation site and pour as per the measurements received in your configuration sheet. Best practices call for the concrete depth to be below the frost line, so we recommend digging the foundation deep enough to extend below the frost line at the installation site.

Call
908-757-2323
or request a quote at
Duragates.com to
get your gate
configured
using our online
calculator.

NOTE: We recommend using reinforced concrete with specified gravity of a minimum of 1.56 lbs/cu ft.

Concrete Pad Considerations

The online configurator calculates the concrete pad dimensions based on the gate opening size (L) and gate weight (P). The pad acts as the counterbalance weight for the gate, allowing for shorter tail sections.

NOTES:

- The pad length is nearly the size of the gate's tail length (ca. 95%).
- The pad dimensions (FAxLxPA) do not take the frost line into consideration and the pad must be deeper than the frost line to prevent frost heaves that may displace the pad.
- The pad dimensions determine the volume of concrete required to provide a counterweight. Any alteration to the length, width or depth of the pad must NOT reduce the volume.
- The pad will often extend under the fence line. This will allow the gate to be placed close enough to the fence line to meet the UL325 entrapment code spacing of <math>< 2\text{-}1/4\text{''}</math>. Distance "A" in the figure on page 11 should be chosen so the edge of the fence is less than 2-1/4" from the edge of the end post or column at the opening.
- The leading edge of the pad should start 9" from the driveway opening

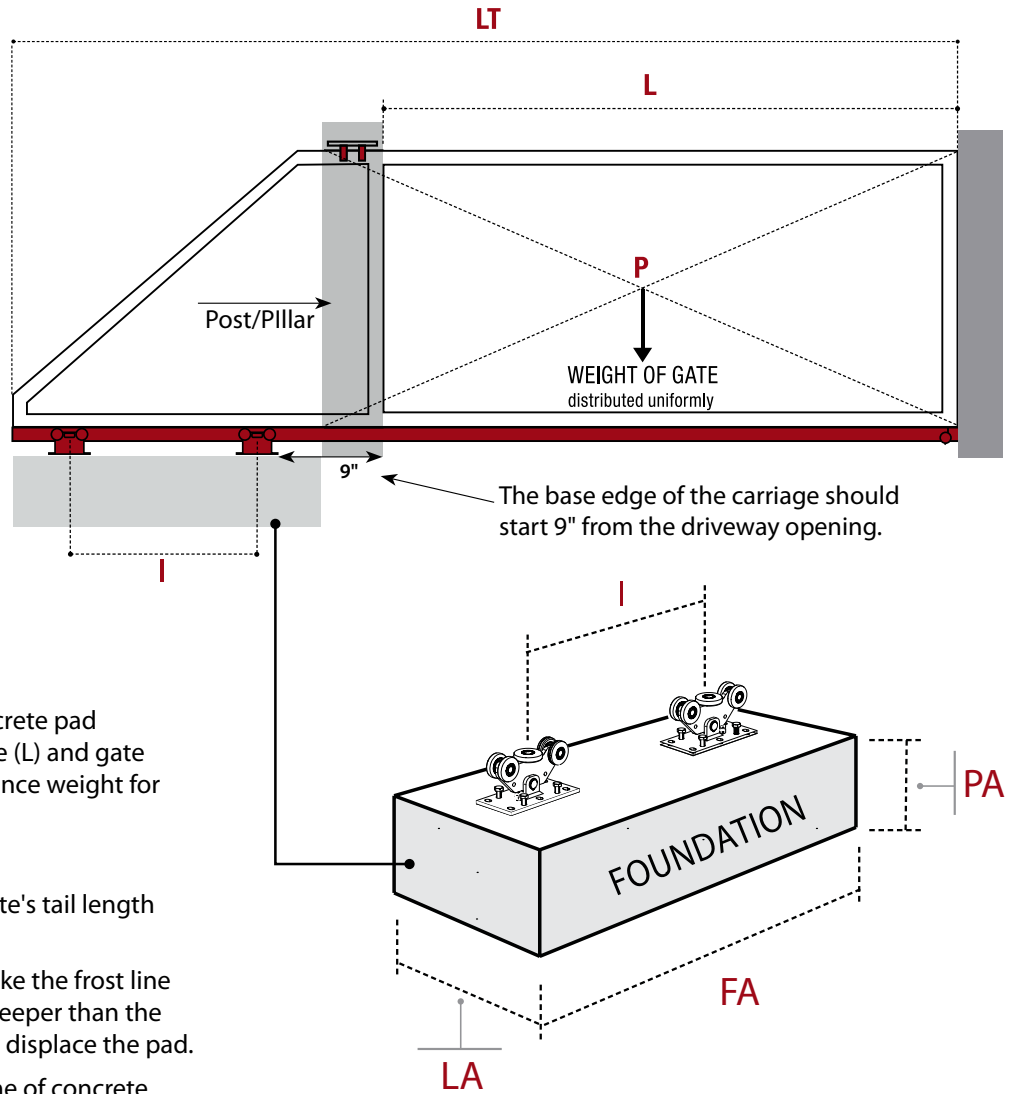

STEP 2 - J-BOLT / TIE ROD INSTALLATION

Once the foundation is prepared, fill the hole with concrete and level to top. Sink or hang the J-Bolts so they are centered "end to end" on the pad, with the leading edge of the front carriage a minimum of 5" from the edge of the concrete. Be sure the center-to-center distance between the carriages is as specified as dimension "I" on the configuration sheet.

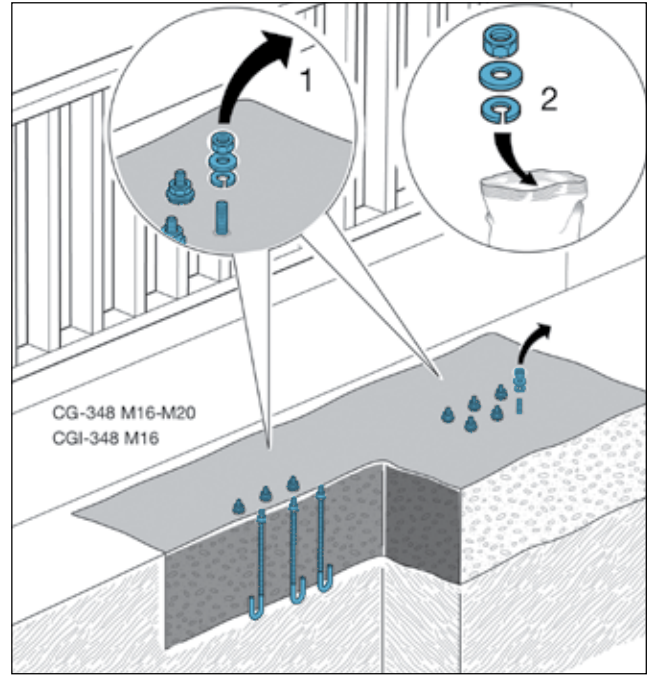

The carriage plate should be no less than 5" from each edge of the concrete slab. Ideally the carriages should be "floated" near the center of the pad if possible.

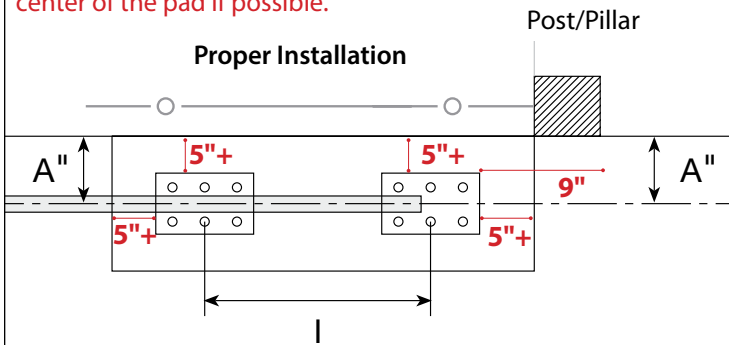

Note: The pad can start under the fence line. This is done to keep the gate face at no more than 2-1/4" from the fence line and to avoid entrapment.

Wrong Installations

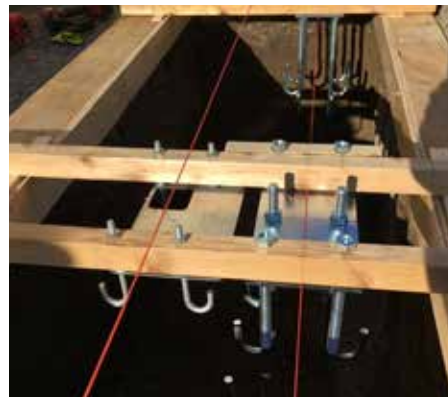
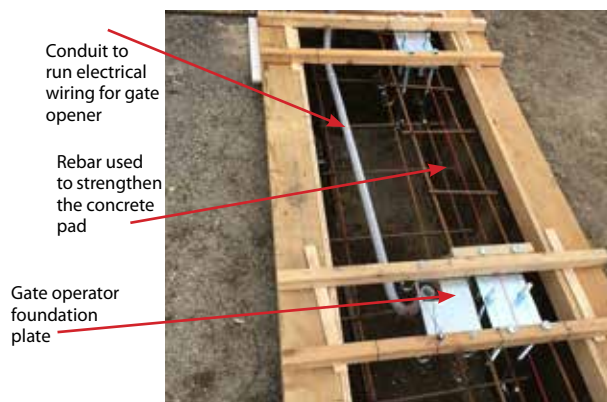
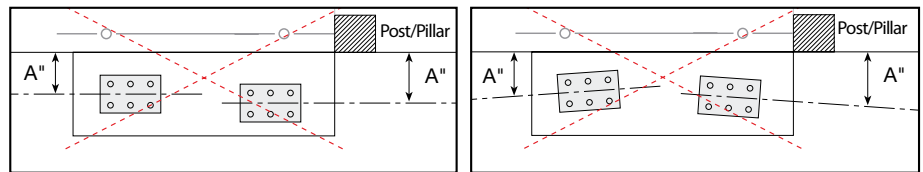

Line up the bolts. Use a string line, template, or other means to ensure bolts are correctly spaced apart per the (I) dimension from the configuration. Line up with the other carriage and run parallel to the gate opening.

Run a string line or laser across the opening to ensure the gate lands at the right point when closed.

Note: The top of the bolt/tie rod should stick out of the cement at least 2". When using a temporary template to set the J-bolts the bottom nut may be sacrificed into the concrete.

STEP 3 - SET THE CARRIAGES

Once the foundation is well hardened, loosen the nuts off the J-Bolts, clean and level the area where the foundation plates or carriages will rest to prepare for the installation of the carriages.

Place the Foundation plates over the J-bolts.

Make sure the orientation of the carriage is correct.

Use the flat and lock washers to secure the carriage to the bolts.

Align and level the carriages, then begin tightening the nuts,

constantly checking that the carriages are level. If they are not level, then adjust the carriage to level, and also level with each other.

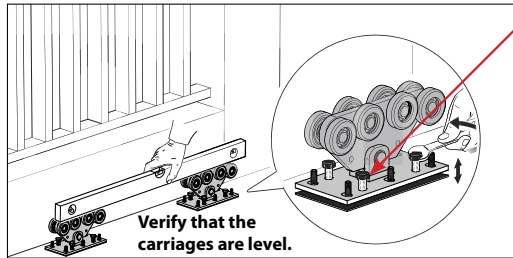
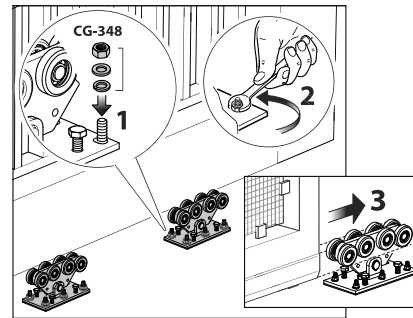
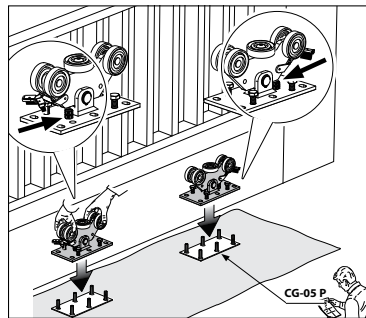
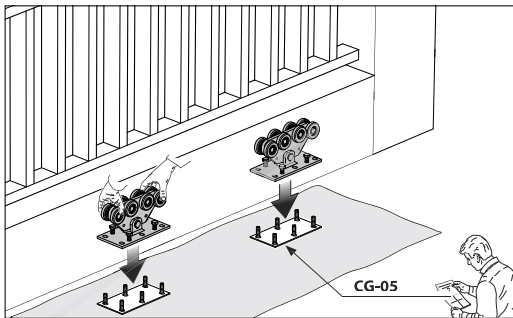
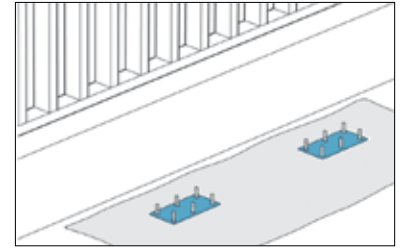
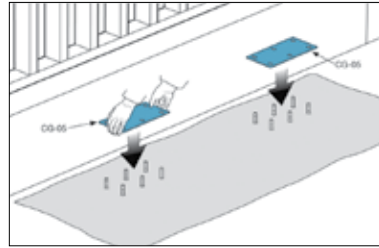

Vertical adjustment jackbolts are available on the "P" & "G" carriage models. They are not available on the "M" carriages.

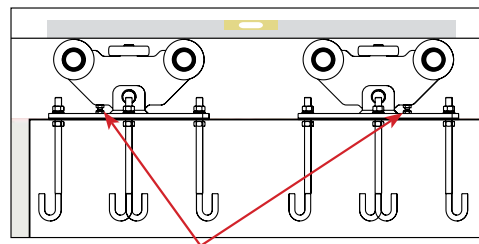

Note: When mounting the CGA carriages, make sure the regulating screws are facing towards the outside as shown in the picture.

If not using foundation plates

Option 1: Carriages will sit on the bottom nuts on the J-bolts to allow plumb/level adjustments using the J-bolts as jack bolts

Option 2: Carriages can be placed directly on the foundation. Plumb/level adjustments must be done by shimming the carriages.

NOTES:

- For Piccolo carriages, the regulating screws should face "outward" and not be installed between the carriages, and for the aluminum P carriage, the sweep brush should also be on the "outside".

Using the CG-05P Foundation Plates with "M" Carriages

The foundation plate has 6 holes, but the "M" carriages only have 4 mounting holes that align with the middle holes and one side of the outside holes as shown.

The diagrams to the right show how to use the CG-05P foundation plates with the CGS-250.8M & CGA-350.5M carriages.

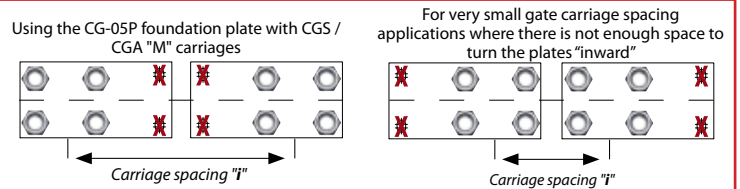

- For carriage installations using the J-bolt as the jack bolt adjustment method, it is best to back fill the space under the carriage with grout to keep the carriage firmly secure over time. This is especially true for heavier gates.

Grout and fill the space under the carriage.



The nut below the carriage can also be used for adjustment.

STEP 4 - ATTACHING THE GATE TO THE TRACK

Attach your gate to the top of the track by welding or mechanically fastening.

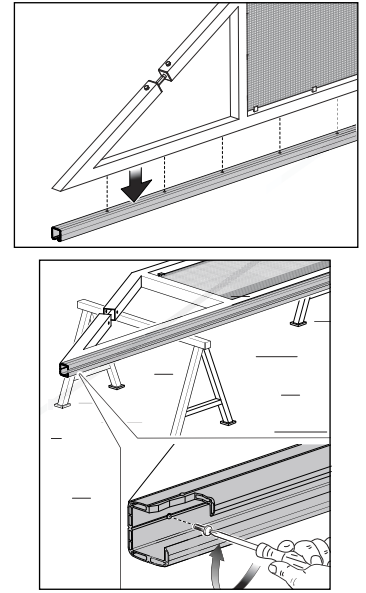
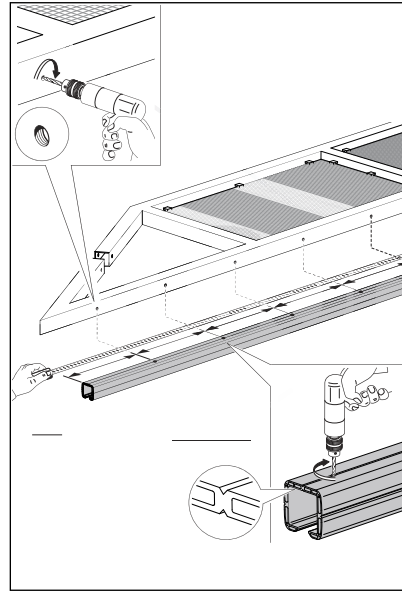
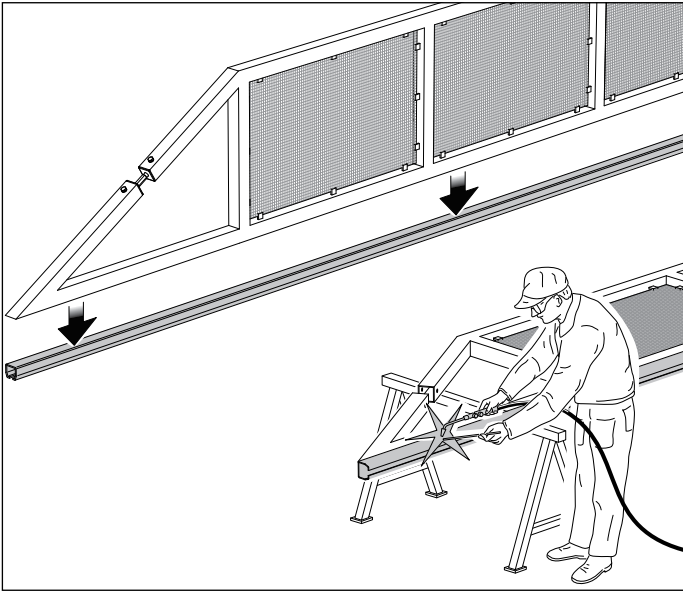

When the gate frame material and the track material are different, you have a few different options. For example, a wood gate on a steel track, a PVC gate on an aluminum track, or an aluminum gate on a steel track.

- 1) Bolt/screw on the gate frame to the track - drill up and thru the top of the cantilever track and bolt the frame to the track. Caution - it's best to use counter sinking bolts/screws so that nothing protrudes into the track cavity to obstruct the carriage wheels. There is a gap in the middle of the wheels on the carriage where a hex head bolt will fit between and not obstruct gate travel, but you must be very careful in size selection and placement.
- 2) Weld small tabs with bolt holes along both edges of the track (like alligator skin). Bolt thru the gate frame and tabs.
- 3) Use a length of flat bar or angle along the bottom length on both sides of the gate frame. Weld this flat bar or angle to the top of the cantilever track and bolt through the gate.

Welding the gate to the track

We recommend stitch welding both sides down the length of the track and gate frame as shown below.



STEP 5 - INSTALL THE END WHEELS

Install the end wheels into both ends of the track. These are recommended to help keep dirt and debris from the inside of the track and for UL-325 compliance. By themselves, they are not a positive stop.

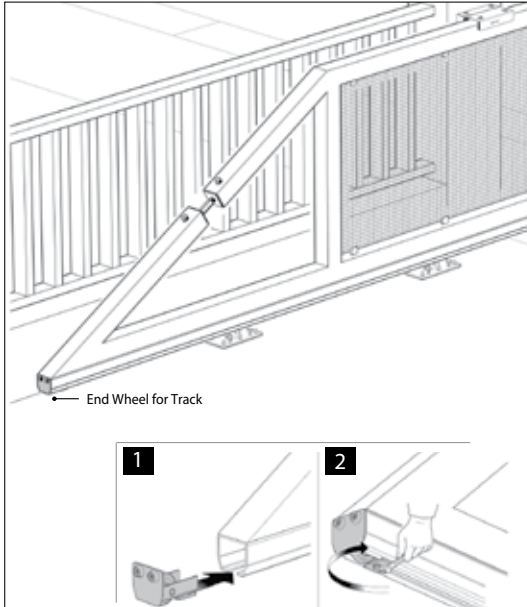

STEP 6 - INSTALL THE MOUNTING BRACKETS

The adjustable mounting brackets are used to hold the bottom end cup.

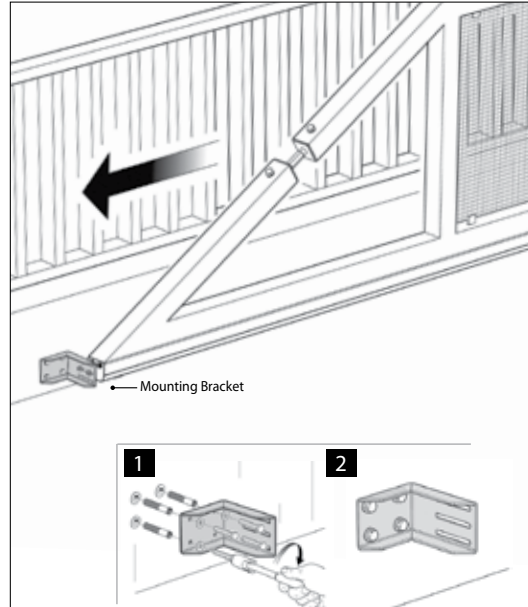

STEP 7 - INSTALL BOTTOM END CUPS TO THE MOUNTING BRACKET

Install the bottom end cups to the adjustable mounting bracket. The bottom end cups provide a positive stop for the gate and eliminate vibration in the gate, extending the life of the carriages.

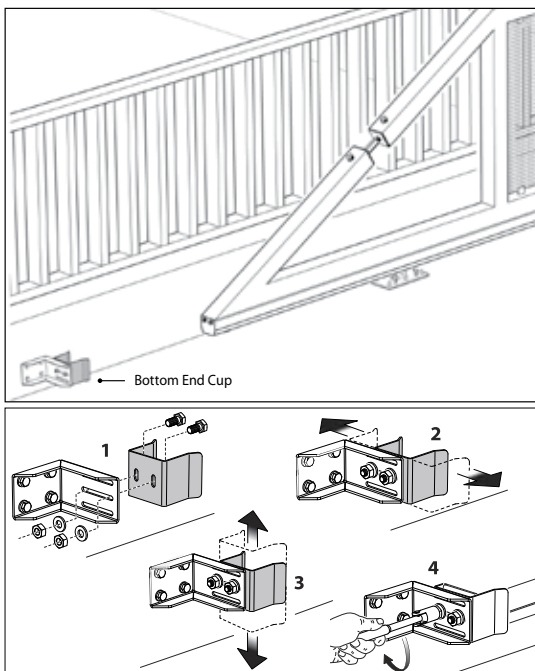

STEP 8 - INSTALL THE GATE RECEIVER

The gate receiver can be installed on the closed side of the gate to keep the gate steady at the top. Install the gate receiver to a mounting bracket.

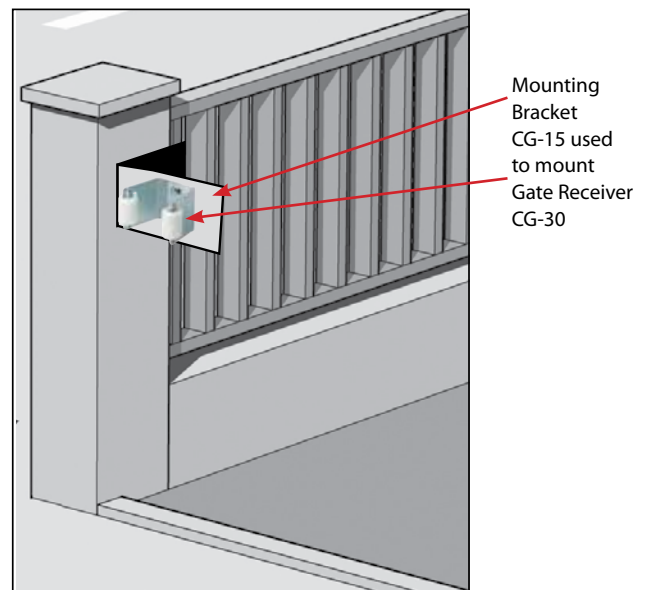

STEP 9 - INSTALL THE TOP GATE GUIDE

The top gate guide is installed on the post near the carriages. The top gate guide keeps the gate vertical under wind loads, but does not support the gate load. For gates longer than 25 feet we recommend using 2 top guides.

Over the top styles: 255-220-C, 256-220 or 256-300

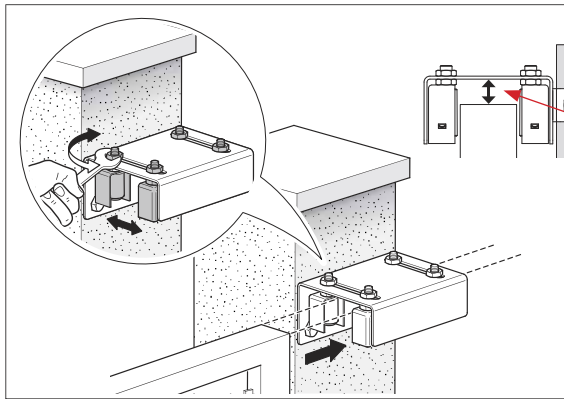

Top clearance dimension is approx 1/8".

See page 8 on choosing a top guide.

If the gate has an arched or decorative top, then the U-channel would be used for a side mount, upper guide option. This style allows for a "hidden" guide and the rollers will not mark the surface of the gate over time. A single roller and a double roller option are available. The U-Channel should be installed at least half way up from the bottom of the gate and above the center of mass of the gate.

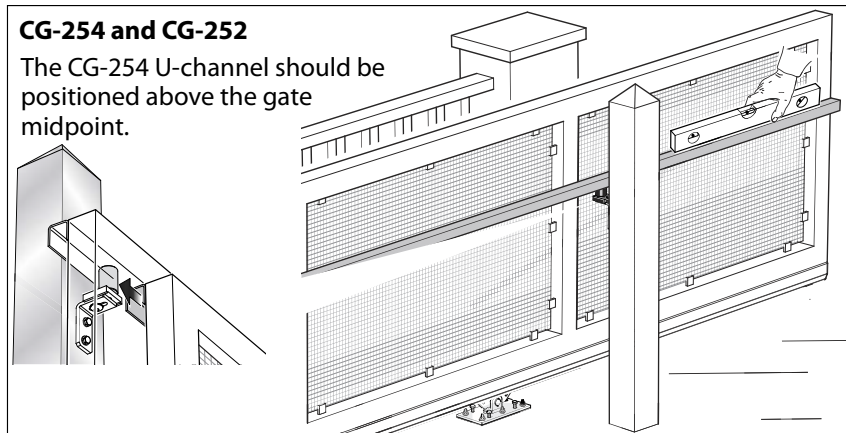

If the U-channel is not an option, then the 10" nylon rollers could be used to support the gate. A post would have to be set on both sides of the gate and a minimum of 2 rollers are needed on each side.

