

CGS-KIT150

An economical cantilever gate hardware kit for lightweight gates up to 13FT in length.

Benefits

- Enclosed roller system helps comply with ASTM F2200 & UL325 safety standards
- Low maintenance
- Minimal visible hardware
- Reduces load on gate operator

Included in CGS-KIT150:

- 2 CGS-150.5M Galvanized Steel Carriages
- 1 CGS-245M-19.68FT Galvanized Steel Track
- 1 CGS-347M End wheel for track
- 1 CGS-346M Bottom end cup for track
- 1 255-220 Top Guide with roller covers

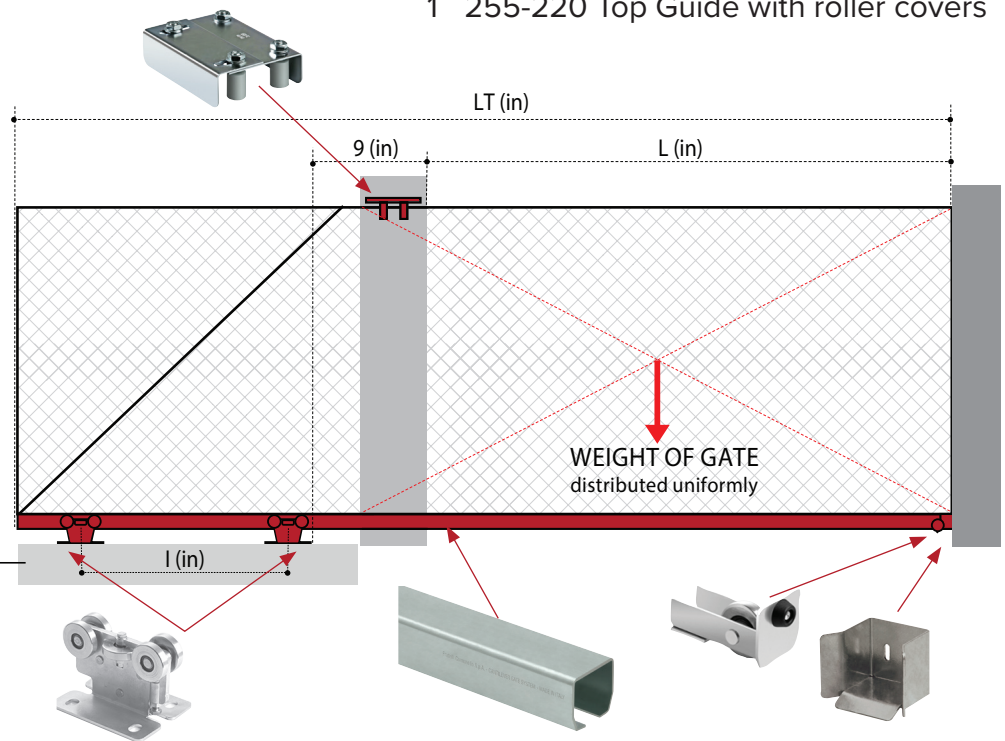
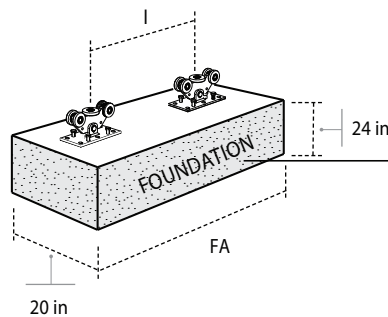

CGS-KIT150

	L = 6'6" (2m)			L = 8' (2.5m)			L = 10' (3m)			L = 11'6" (3.5m)			L = 13' (4m)		
Weight (lb)	FA (in)	I (in)	LT (in)	FA (in)	I (in)	LT (in)	FA (in)	I (in)	LT (in)	FA (in)	I (in)	LT (in)	FA (in)	I (in)	LT (in)
200	36	12	124	38	14	143	39	16	169	41	18	190	41	18	207
220	36	12	124	39	16	145	39	16	169	41	18	190	43	20	209
275	39	16	128	39	16	145	43	20	173	45	22	194	49	26	215
330	39	16	128	43	20	149	47	24	177	49	26	198	53	30	219
400	43	20	132	47	24	153	51	28	181	57	34	206	61	38	227
440	47	24	136	51	28	157	55	32	185	61	38	210			
550	55	32	144	59	36	165	66	44	197						
660	63	40	152	75	52	181									