

Accommodates up to 4000 lbs
with a 59 ft opening

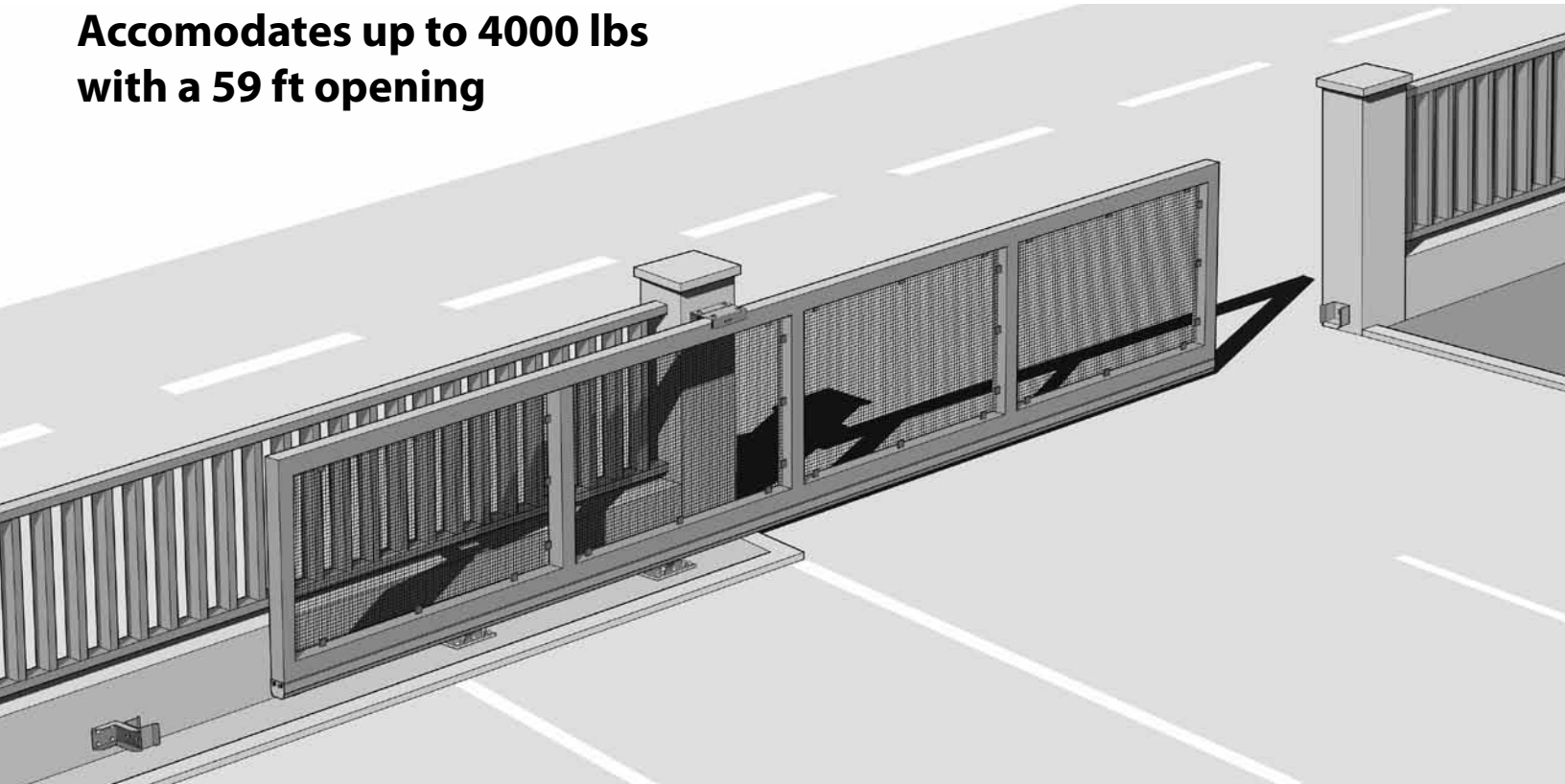

High Performance Cantilever Gate Hardware

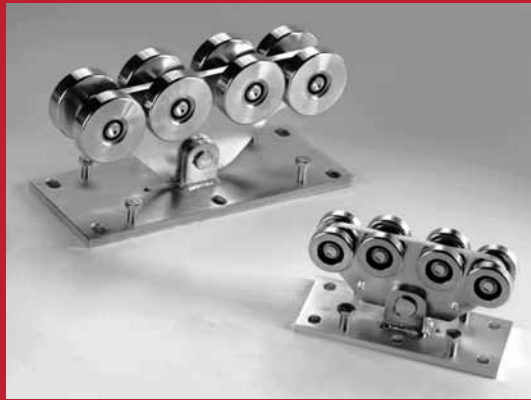
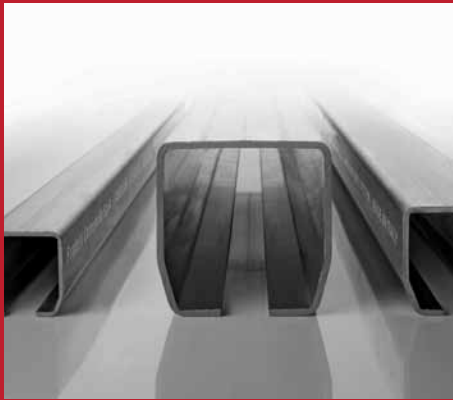

Manufactured in Italy by

COMUNELLO
LIFE MADE EASY



Scan code
to watch
video

The **COMUNELLO** Cantilever gate hardware offers a professional solution which avoids many of the maintenance problems with traditional sliding gates and satisfies your requirements for installing a cantilever gate, even with complicated applications or large dimensions. It is the perfect choice, with its complete line of accessories and a product configurator to calculate the correct dimensions for the gate.

Moreover, the hardware can be used on any gate material. **Steel / Aluminum / Stainless Steel / Wood / Chainlink / Vinyl.**

Shown: 350.8 Professional Range
Accommodates up to 4,000 lbs.
or up to 59 ft. opening.

Slide gate automation also available

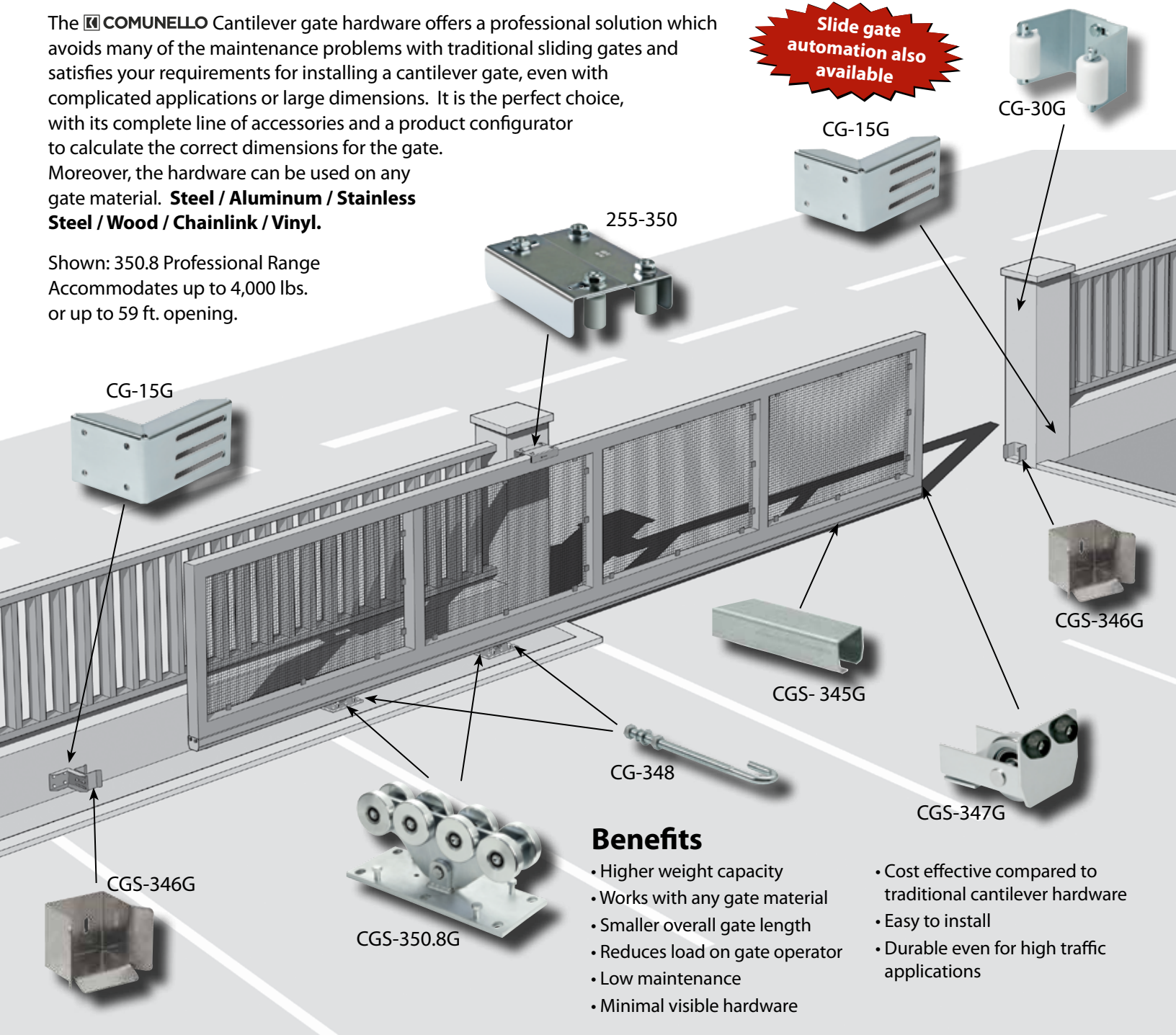

Benefits

- Higher weight capacity
- Works with any gate material
- Smaller overall gate length
- Reduces load on gate operator
- Low maintenance
- Minimal visible hardware
- Cost effective compared to traditional cantilever hardware
- Easy to install
- Durable even for high traffic applications

NOTE: WE ONLY SUPPLY THE HARDWARE, NOT THE GATE ITSELF

Call us at:
800-784-7444

for **FREE** assistance in configuring the specifications for your cantilever gate project.



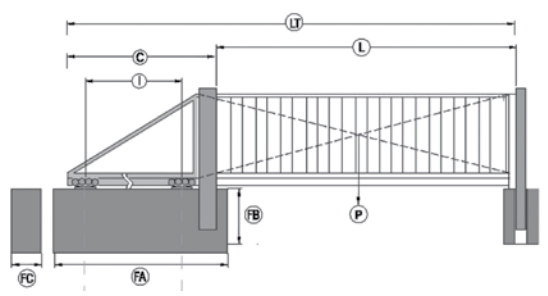







- Based on the gate dimensions, we can supply you with:
- Length of counter balance
 - Load calculations
 - Bill of materials
 - Installation instructions



950 South 2nd Street, Plainfield, NJ 07063
Ph: (800) 784-7444 or (908) 757-2323 | Fax: (908) 757-3439
www.duragates.com | info@duragates.com

GALVANIZED STEEL TRACK

ALUMINUM TRACK

Model	CGS - 350.8G	CGS - 350.8P	CGS - 250.8P	CGS - 250.8M	CGA 350 P	CGA - 350.5M
Weight & Opening Range	Up to 4050 lb. Opening of 59.4 ft	Up to 1700 lb. Opening of 26.4 ft.	Up to 1300 lb. Opening of 19 ft	Up to 900 lb. Opening of 13 ft.	Up to 708 lb. Opening of 26.4 ft.	Up to 550 lb. ★ NEW Opening of 16 ft.
Carriages						
	CGS-350.8G Large Carriage Monobloc Body	CGS-350.8P Medium Carriage Monobloc Body	CGS-250.8P Medium Carriage Multiplate Body	CGS-250.8M Small Carriage Multiplate Body	CGA-350P For Aluminum Gate 5 Nylon Wheels 	CGA-350.5M For Aluminum Gate 5 Nylon Wheels
Tracks						
	CGS-345G Large Galvanized Track	CGS-345P Medium Galvanized Track	CGS-245P Medium Galvanized Track	CGS-245M Small Galvanized Track	CGA-345P Aluminum Track 	CGA-345M Aluminum Track
Accessories						
	CGS-347G End Wheel for Track	CGS-347P End Wheel for Track	CGS-347P End Wheel for Track	CGS-347M End Wheel for Track	CGA-347P End Wheel for Track	CGA-347M End Wheel for Track
	CGS-346G Bottom End Cup for Track	CGS-346P Bottom End Cup for Track	CGS-346P Bottom End Cup for Track	CGS-346M Bottom End Cup for Track	CGS-346P Bottom End Cup for Track	CGA-346M Bottom End Cup for Track
	CG-15G Adjustable Wall Mounting Bracket	CG-15P Adjustable Wall Mounting Bracket	CG-15P Adjustable Wall Mounting Bracket	CG-15M Adjustable Wall Mounting Bracket	CG-15P Adjustable Wall Mounting Bracket	CG-15M Adjustable Wall Mounting Bracket
	CG-30G Upper Adjustable End Cup	CG-30P Upper Adjustable End Cup	CG-30P Upper Adjustable End Cup	CG-30M Upper Adjustable End Cup	CG-30P Upper Adjustable End Cup	CG-30M Upper Adjustable End Cup
Anchoring and Installation Accessories						
	CG-348-M20 Threaded Tie Rod for Carriage	CG-348-M16 Threaded Tie Rod for Carriage	CG-348-M16 Threaded Tie Rod for Carriage	CG-348-M16 Threaded Tie Rod for Carriage	CG-348-M16 Threaded Tie Rod for Carriage	CG-348-M16 Threaded Tie Rod for Carriage
	CG-05G Foundation Plate	CG-05P Foundation Plate	CG-05P Foundation Plate		CG-05P Foundation Plate	

CGI-40

Tension Bars - Stainless Steel

*Used for minor adjustment
when gate sags*

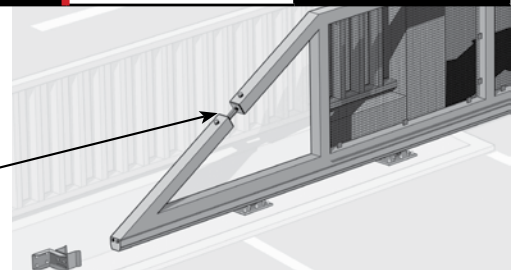

TOP GUIDE OPTIONS

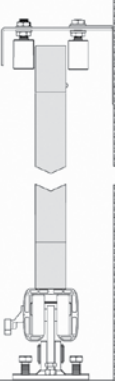



**Adjustable
guiding plate**

255-220
For 1¼" - 2¾" frame

255-350
For 2¾" - 3¾" frame

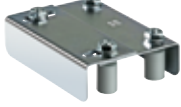
CG-251
For 2¾" - 4¾" frame





Adjustable support roller

CG-252

Monorail for CG-252

CG-254



10" nylon roller for support

253

Use at least
2 per gate



USE FOR GATES WITH AN ARCHED TOP

Frequently Asked Questions

Q: Where do I start?

A: The first step is to think about what kind of gate design and gate material you want. The advantage of using our hardware is that you can use practically any gate design with any gate material. Then, let us know the size of the opening and the approximate weight of just the opening part of the gate. We will then come back to you with the suggested model, overall length of gate including counterbalance and size of the foundation required. Armed with that information you can then complete your gate design.

Q: I have seen most cantilever track with a top track system. What are the advantages of the Duragates system over the top track system?

A: There are several advantages actually.

- First of all, the weight of the gate is transferred to the ground, hence it can bear a lot more load than a top track. Besides there are less chances of the track bending/buckling
- You can use any gate material versus mainly steel/aluminum for the top track system
- You can design any gate shape versus only a straight gate for the top track
- Performs better in the snow
- Looks much better versus the industrial look of the top track system
- Our system needs a smaller counterbalance versus the top track thus reducing the overall gate length
- You don't need an elaborate system of posts to mount the gate to. Posts tend to shift over time causing problems in the future. Our system only needs a top guide plate that can be installed even on masonry columns

Q: Can I use any gate material?

A: Yes, you can use practically any gate material as long as you can mechanically attach the gate to the bottom track. In case of a steel or aluminum gate you can just weld the gate to the track, or even use the track itself as the bottom frame of the gate.

Q: The system looks very simple. What am I missing?

A: You are not missing anything! The system is actually very simple. Just a track, 2 wheels and some related accessories. Not just that, it is also very aesthetically appealing with minimal visible hardware.

Q: I live in very heavy snow conditions. How does it perform in these conditions?

A: The product actually works better in the snow than most traditional sliding gate hardware systems.

- The wheels are always covered with the track, hence you never have to clean the wheels.
- There are no exposed rollers unlike some other cantilever systems
- The path of the gate travel has to be cleared of snow, which would have to be done for any gate
- You may have to adjust the foundation depth based on the frost line in your local area

Q: I don't know the weight of my gate. Where do I go from here?

A: We urge you to at least roughly estimate the weight of the gate based on the materials and design used. It is an important starting point in order for us to help you configure the overall gate dimensions.

Q: My gate is very small. Can I use your system?

A: Absolutely. Our system can be used for openings as small as 2 to 3 ft in residential and even indoor applications. You don't need to pour a foundation for small gates/doors such as these. See our project gallery for examples.

Q: Which gate operator can I use?

A: Our system is totally independent of the gate operator. You can use a gate operator of your choice. In fact the face of the bottom track provides a nice surface to mount the gear rack to (for rack/pinion type operators). The track slides very smoothly on the carriages thereby reducing the load on the operator.

Q: What kind of maintenance does it require?

A: None really. The carriages have sealed bearings. Depending on usage the bearings may wear out eventually and is then advisable to replace the entire carriage. If you ever want to service the gate, simply remove the end caps and slide the gate off the track.

Q: How much effort will I need to operate the gate?

A: The track slides very smoothly on the carriages and you can operate the gate with just one hand. Of course, depending on the weight of the gate and the application you may want to install a gate operator. Due to the smooth operation, the load on the operator is also reduced.

Q: Can the gate travel at an incline?

A: Unfortunately that is one application where the gate won't work. The carriages have to be installed horizontally and in one line. However, since it is cantilevered off the ground, the ground itself can be at an incline. You just have to install the gate high enough to clear the highest point on the ground.

Q: Can I install the carriages on a post instead of on the ground?

A: We highly discourage installing the carriages on the post as it will not be able to bear a high load and will also cause problems once the post starts to shift. In fact the system is designed to avoid all the problems associated with mounting the carriages to a post. We realize that there is an added cost involved in making a foundation. However for light duty applications, many of our customers have been able to post mount the carriages or not pour a foundation. Once you understand how the system works, please use your judgment to determine what could work in your application.

Q: I have an arch top on my gate. What do I use for the top guide?

A: For arched and other gate shapes we recommend using the monorail CG-254 and the roller CG-252. This galvanized steel monorail can be installed horizontally somewhere along the full length of the gate and will provide adequate support.

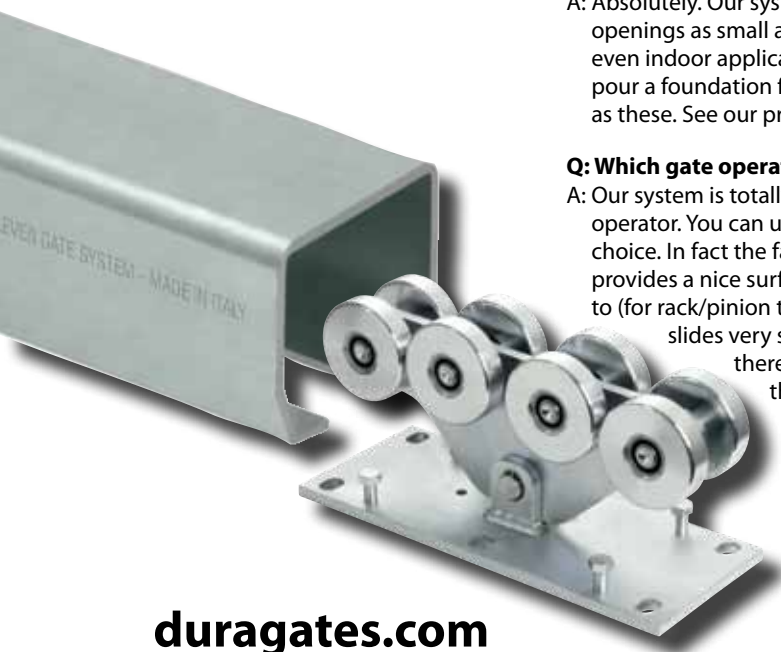

duragates.com

Call **800-784-7444**
for your next sliding
gate project!

WHY CHOOSE DURAGATES OVER OTHER SLIDING/ROLLING GATE SYSTEMS?

DuraGates enclosed roller system

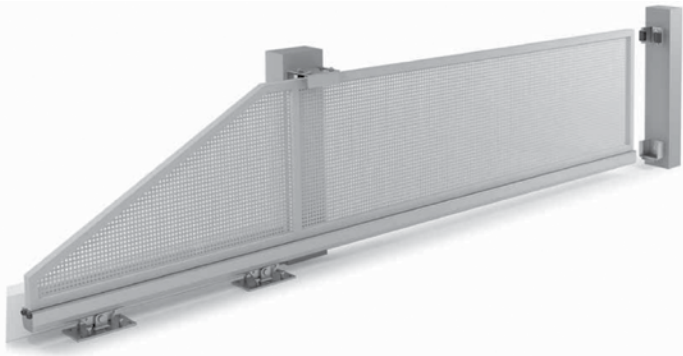

Benefits of using DuraGates Hardware!

- **Higher Weight Capacity**
With the weight of the gate transferred to the ground, gate openings up to 59 feet with a weight of 4000 pounds can be accommodated.
- **Use with any Gate Material**
The gate can be either welded or mechanically attached to the bottom track.
- **Smaller Overall Gate Length**
The counterbalance is less than traditional cantilever hardware which works especially well when space is restricted.
- **Easy Installation**
Once the 2 carriages are mounted on the concrete pad, simply slide the gate on the carriages and add the end wheels.
- **Durability**
High quality rollers and track result in years of troublefree operation.
- **Reduced Load on Gate Motor**
The gate will roll smoothly and can even be operated with one hand. This reduces the load on the gate motor resulting in a longer life and reduced maintenance on the motor.
- **Low Maintenance**
Enclosed, sealed bearing equipped roller construction, no lubrication required! The sealed bearings really stand up to dusty environments where grit would eat up non-sealed bearing designs. Great in snowy, icy, rainy...basically any environment as the rollers are enclosed inside the track and are not affected by precipitation.
- **Minimal Visible Hardware**
Since no unsightly wires or overhead track are needed with DuraGates, our hardware makes for a more aesthetically pleasing gate system. It can also be adapted for a gate with an arched top.
- **Unobstructed Driveway**
No track on the ground to trip over. The driveway can be uneven and sloping since the gate is off the ground.

V-track systems

Pros:

- Nice slide action if there is nothing in the way of the rollers like a garden hose, rock, or other obstruction.



Cons:

- Needs digging of trench along length of driveway for proper installation.
- Ground track can be obstructed by objects laying over it.
- Rollers can possibly be derailed.
- In freezing weather, snow and ice can obstruct the track, and when the gate is open, the track would potentially be in the way of snow plowing.
- In freezing weather the rollers can freeze up, compromising the smooth slide action of the gate.

Overhead track systems

Pros:

- Sometimes a closed roller system, meaning the rollers are sheltered from the elements within the track, this way snow and ice doesn't impede the rolling action of the gate.



Cons:

- Bearings used in these systems are not commonly a sealed bearing, so maintenance is required, grease must be used to keep the bearings within the trucks rolling smoothly. This type of lubrication accumulates grit, especially in dusty environments and requires a cleaning of the track and roller surfaces to maintain a smooth gate action.
- Overhead systems usually do not work with gates that are meant to be ornamental or even just aesthetic, the track looks quite industrial from the outside if it is not hidden by the gate.
- It is not possible to do an arched top gate.
- Gate is constantly pulling down on the track resulting in limited weight capacity.

Chainlink exposed-roller systems

Pros:

- Economical: Because this type of system uses the bottom pipe of the chainlink gate as a track, there is no track to purchase. This means that all you have to buy are rollers to support and guide the gate.



Cons:

- These gates have practically no aesthetic appeal, this is why they are commonly used in industrial applications.
- Due to using the chainlink panel frames as the channel for the rollers, the gate itself can get quite dirty from lubrication of the rollers getting onto the gate frame.
- These gates can have the least smooth action.
- The rollers are exposed and need constant cleaning.
- Needs at least 50% counter balance
- As the gate posts may eventually shift, the rollers may need constant adjustment.



A Division of

Architectural Iron Designs, Inc.

950 South 2nd Street
Plainfield, NJ 07063
www.duragates.com

Mfg. in Italy by



Scan code to
watch video



DuraGates hardware allows for a beautiful gate with an arched top.



This high profile project has a unique lattice work design. Any regular sliding gate hardware would have compromised the aesthetic appeal of the gate.



Vinyl privacy fence in a residential neighborhood.



Moving wall to separate the Pediatric lobby at Golisano Children's Hospital in Rochester, NY.



Aluminum sliding gate on a slope going down to the river!

Visit duragates.com to see more applications of sliding gate hardware.